

EET Excavator Suction Strainers



Technical specification

Application:	Suction strainers for in-tank mounting
Port size:	Ø 48.5 mm to Ø 154.5 mm
Flow rate:	max. 1400 l/min
Element collapse pressure:	1 bar
Seals:	NBR or FKM (-10°C to 100°C)
Material:	SECC end caps & core
Compatibility:	Suitable for mineral oils, lubrication oils, non-flam fluids, synthetic and rapidly biodegradable oils according to ISO2943 (for use with water, please contact our technical dept.)
Tested according to ISO standards:	ISO2942 Fabrication integrity ISO2943 Material compatibility integrity ISO3723 Method for end load test ISO3968 Pressure drop vs. Flow

Technical specification subject to change without prior notice. Other specification on request. 2015/10/15

Pressure drop graphs (Δp)

Pressure drop of clean filter elements (wire mesh filter media)

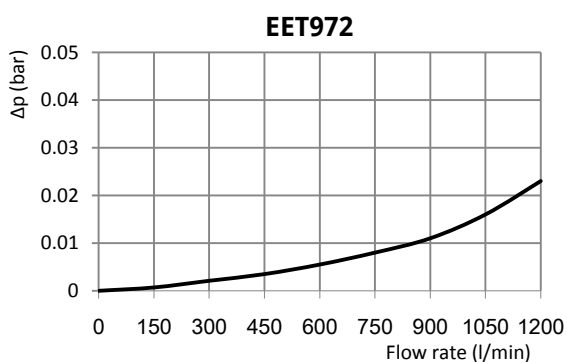
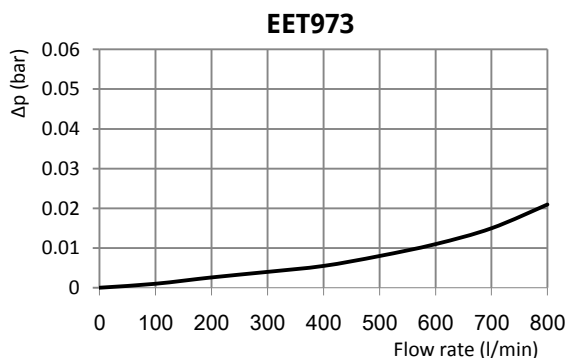
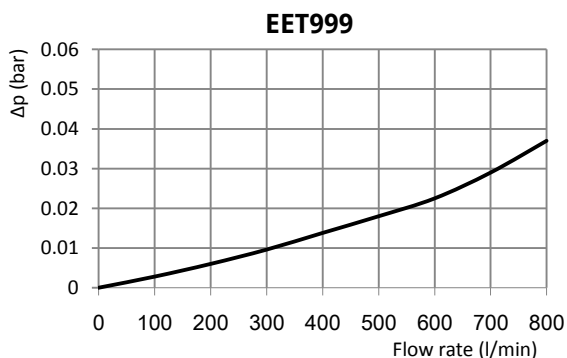
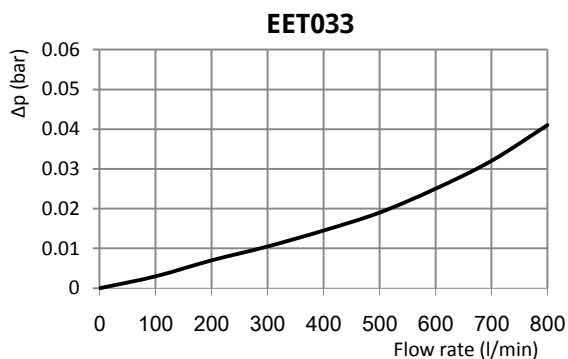
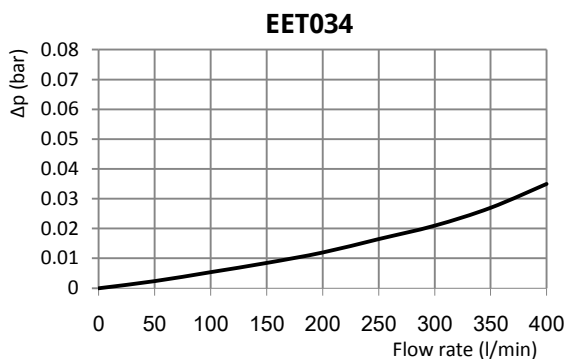
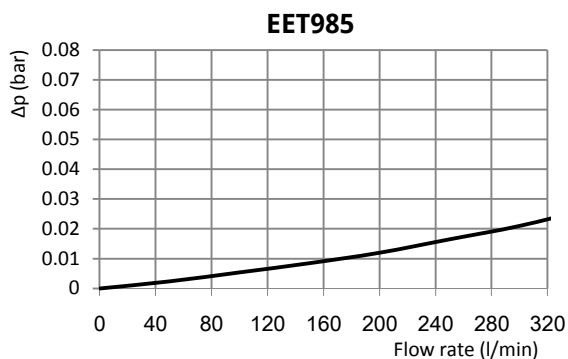
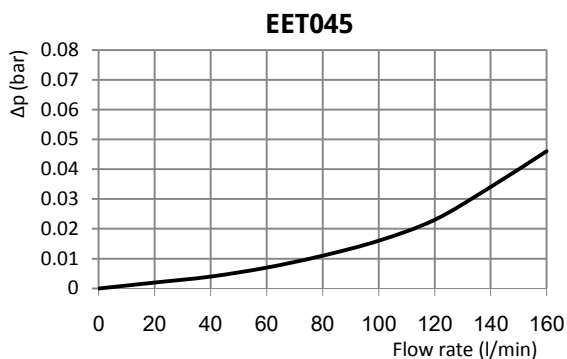

The test fluid has a density of 0.86 kg/dm³ and a kinematic viscosity of 30 mm²/s.

Dimensional drawings

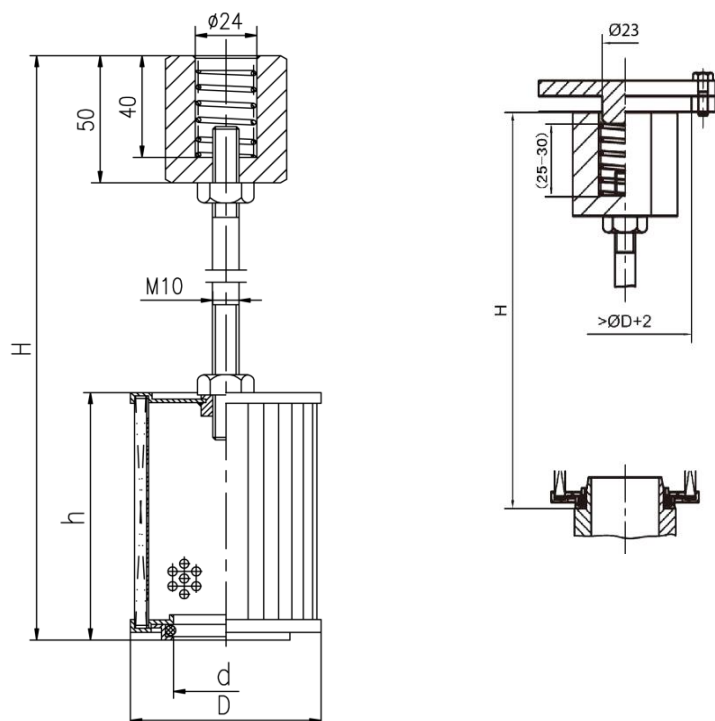

Order information

Element part number

Element							
Type	Size	Media	Seals	h	H	Special	
EET	Table 1	Table 2	Table 3	Table 1	Table 1	Table 4	
Example	EET	985	W100	B	150	x	- 680

Tables

Table 1					
EVO size	Flow rate (l/min)	d	D	h	H
EET045	140	48.5	90	143	205 - 755
EET985	330	59.5	120	100 - 200	270 - 780
EET034	350	61.0	125	163	270 - 780
EET033	500	89.5	150	135 - 300	305 - 810
EET999	600	100.0	150	98 - 195	305 - 810
EET973	1000	114.5	200	195 - 385	305 - 810
EET972	1400	154.5	200	390	500 - 1060

Table 2			
Media	Material	Filtration	Collapse
W60	Wire mesh	60 μm	1 bar
W100	Wire mesh	100 μm	1 bar
W180	Wire mesh	180 μm	1 bar

Table 3	
Seal	Material
B	NBR
V	FKM

Table 4	
Special	
x	none
22	Spring holder inner ϕ 22 mm
25	Spring holder inner ϕ 25 mm
M12	Rod ϕ M12

The tables represent standard models only. Height of the element (h) and the total height (H) can be produced according to request.

Different connection (d) and outer diameters (D) can be produced on request for higher quantities as well.